

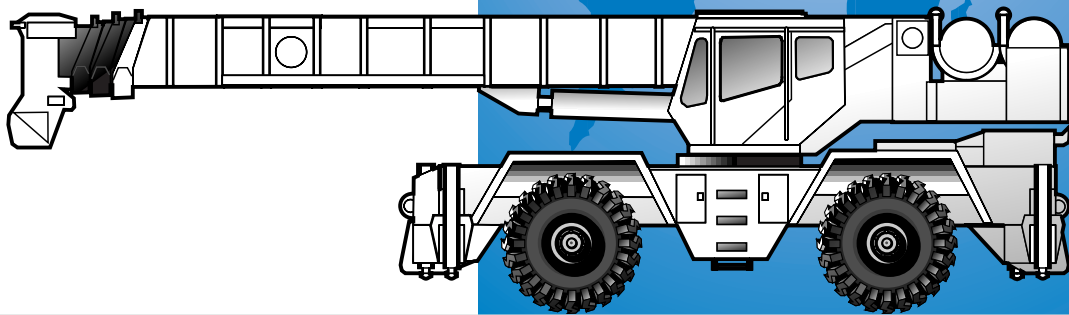

GROVE[®]
CRANE

RT860



Rough Terrain Crane

Grue Tout Terrain

Geländekran

Grúa Todo Terreno

METRIC

Dimensions
Abmessungen
Encombrement
Dimensiones

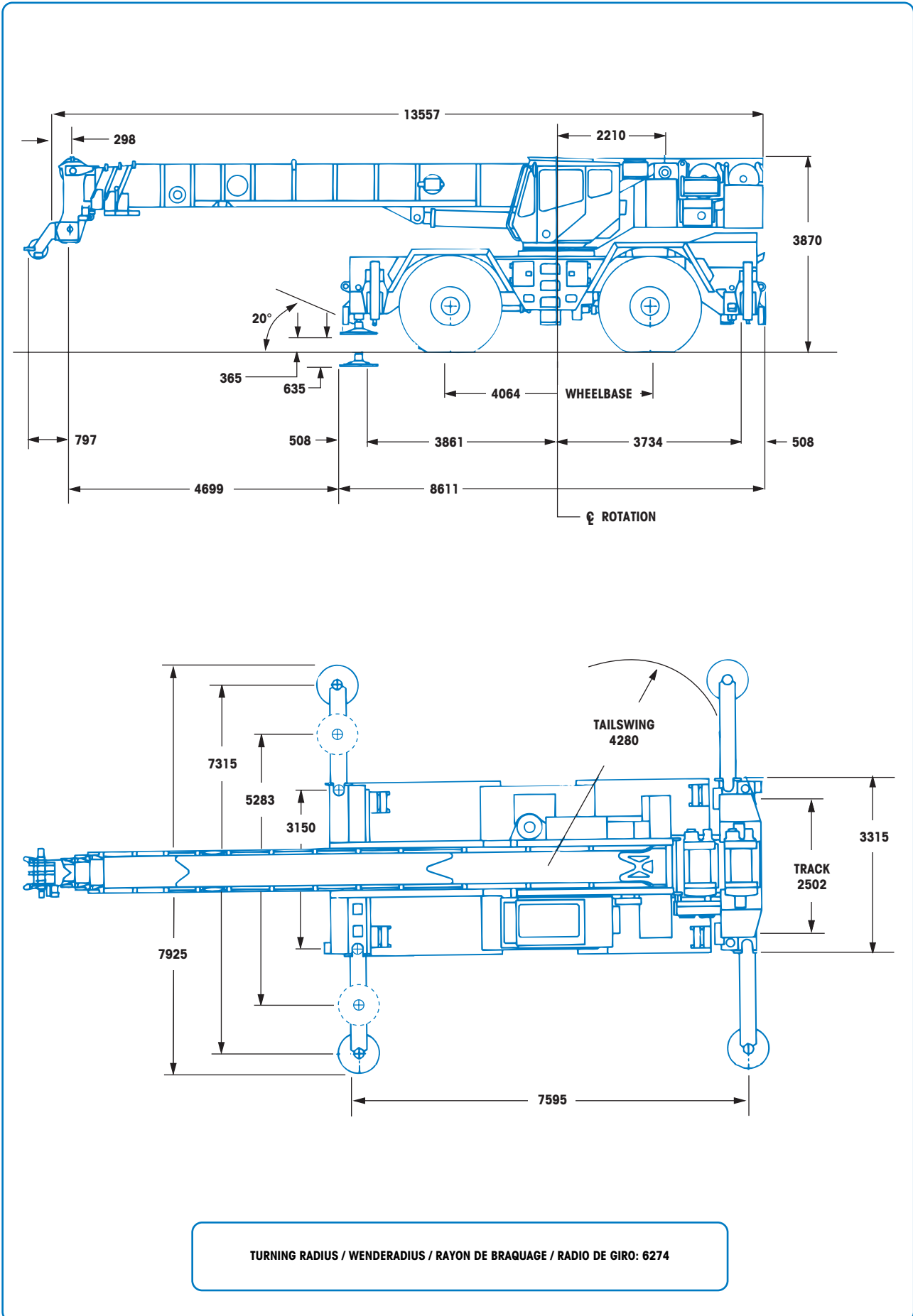

Working range
Arbeitsbereiche
Portée flèche
Gama de trabajo



11.3 – 35.1 m



10.7 – 18.3 m



360°

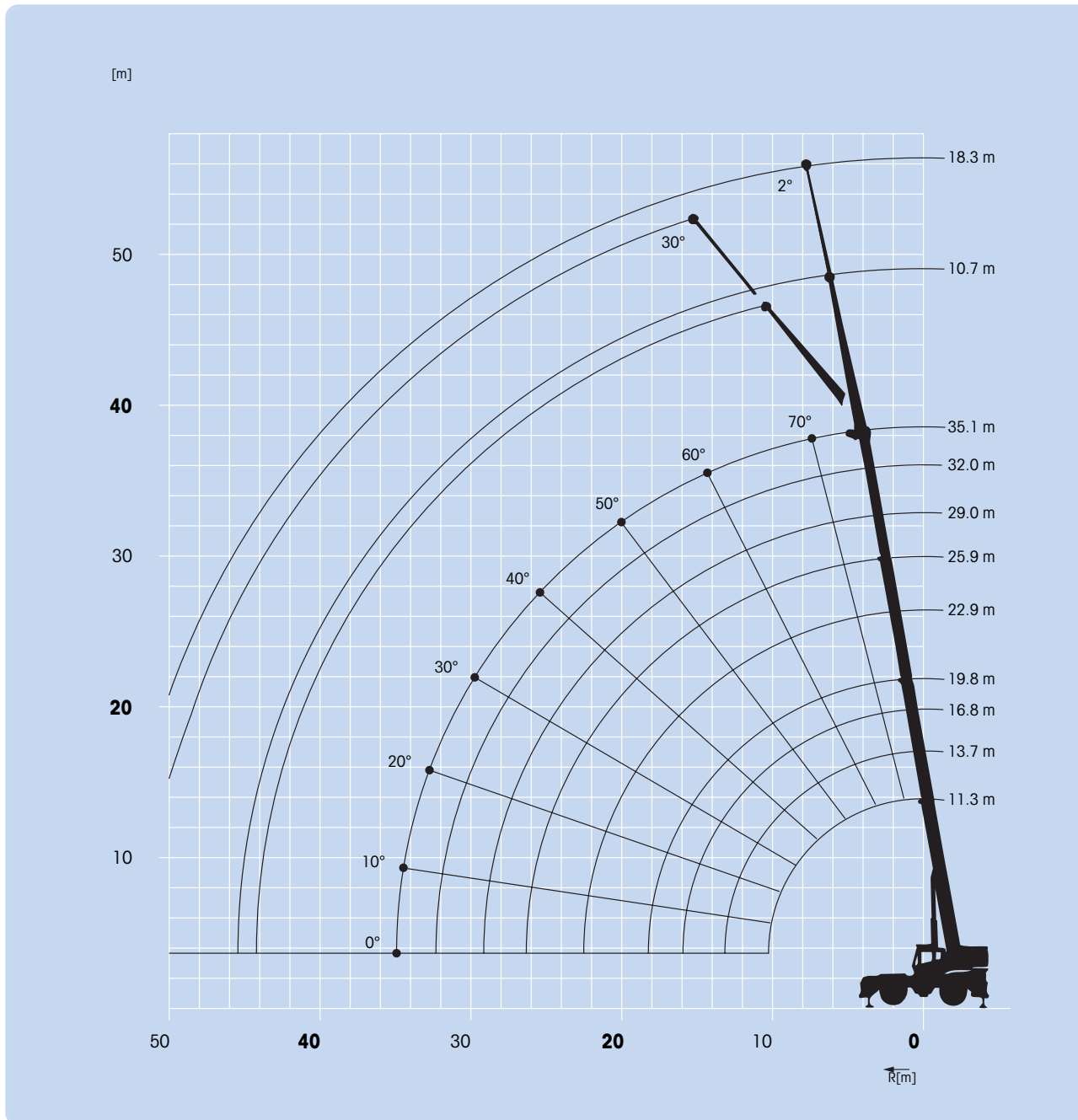

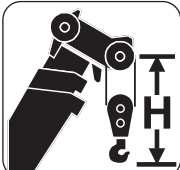
	Hook block • Unterflasche • Crochet-moufle • Gancho (t)	H (mm)
	55	2134
13.6	2023	
9.1 H/B	1676	
—	—	

Weights/Working speeds
Gewichte/Geschwindigkeiten
Poids/Vitesses
Pesos/Velocidades de trabajo



Axle Achse Essieu Eje	1	2	Total weight Gesamtgewicht Poids total Peso total
†	22.0	21.0	43.0 *

* incl. 10.7 m Swingaway, incl. 10.7 m Klappspitze, incl. extension treillis 10.7 m, incl. plumín de 10.7 m



Lifting Capacity Traglast Force de levage Capacidad de elevación	Sheaves Rollen Pulies Poleas	Parts of line Stränge Brins Ramales de cable	Weight Gewicht Poids Peso
55 t	5	2 - 10	578 kg
13.6 t	1	1 - 3	179 kg
9.1 t	H/B	1	254 kg



+

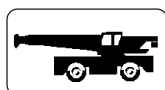

	1 (F & R)	2 (F & R)	3 (F & R)	
km/h	9	17	40	
km/h	4	7	19	74%
	29.5 x 25			



+



	Infinitely variable stufenlos progressivement variable Infinitamente variable	Rope Seil Câble Cable	Max. permissible line pull Maximal zulässige Seilzugkraft Effort maximum autorisé sur brin simple Potencia máxima admisible por ramal
	0 - 157 m/min single line für einfachen Strang au brin simple ramal simple	19 mm/168 m	5860 kg
	0 - 157 m/min single line für einfachen Strang au brin simple ramal simple	19 mm/168 m	5860 kg
	0 - 2.0 min ⁻¹		
	20° to + 70° approx. 39 s ca. 39 s env. 39 s aproximadamente 39 s		
	11.3 m to 35.1 m approx. 110 s ca. 110 s env. 110 s aproximadamente 110 s		

Superstructure specification

Boom

11.3 m to 35.1 m four section full power boom, including standard auxiliary boom nose. Maximum tip height 38.0 m.

Swingaway

10.7 m to 18.3 m telescopic lattice swingaway. Offsettable at 2° or 30°. Maximum tip height 56.0 m.

Boom elevation

1 cylinder with safety valve, boom angle from -3° to 78°.

Load moment and anti-two block system

Load moment and anti-two block system with audio-visual warning and control lever lock-out. These systems provide electronic display of boom angle, length, radius, tip height, relative load moment, maximum permissible load, load indication and warning of impending two block condition.

Cab

Galvanealed steel, acoustically treated, opening skylight with electric wiper, deluxe seat with armrest-integrated crane controls, hydraulic oil heater. Ergonomically arranged instrumentation and crane operating controls. Drive/steer controls.

Slewing

360° continuous rotation, planetary glide swing with foot applied brake. Spring applied hydraulically released parking brake and plunger type, 1 position mechanical house lock and 360° mechanical slew lock operated from cab.

Counterweight

4,310 kg removable, plus slab in place of auxiliary hoist.

Hydraulic system

7 main gear pumps combined capacity 754 l/min. Return line filter with by-pass protection. Remote mounted thermostatically controlled oil cooler and system pressure test panel. Tank capacity: 757 l.

Control system

Stepless control of all crane movements using single axis hydraulic pilot control levers with automatic reset to zero.

Hoists

Main and auxiliary hoists, each with two vane motors, planetary gear, dual speed with automatic spring applied multi-disc brake. Grooved drum, hoist drum cable followers and electronic rotation indicator.

*Optional equipment

11.3 - 27.1 m three section full power main boom.

10.7 m lattice swingaway (offsets 2°, 30°).

Counterweight removal system.

High Speed Glide System.

Remote grease system for turntable.

Air conditioning.

Propane cab heater.

Dual axis joystick control levers.

LMI light bar.

Carrier specification

Carrier frame

Special 2-axle carrier, all-welded torsion-resistant box type construction in high strength steel. Integral towing and tie down lugs.

Outriggers

4 hydraulically telescoping beams with 'inverted' jacks and 610 mm diameter outrigger pads. Independent horizontal and vertical movement control from the crane operator's cab. Three position setting. Sight level gauge. Maximum outrigger pad load: 41,992 kg.

Engine

Cummins 6CTA8.3L, 6 cylinder water cooled, turbocharged and after cooled diesel. 186 kW (250 bhp) at 2200 rpm. Max. torque: 1077 Nm at 1500 rpm. Fuel tank capacity: 303 l. Engine emission: EUROMOT / EPA / CARB (non road).

Transmission

Clark powershift 32000 series, 6 forward and 6 reverse speeds.

Drive/Steer

4 x 4 x 4

Axles

2 axles driven and steered. Rear axle disconnect for 4 x 2 travel.

Suspension

Front axle rigid mounted to frame. Rear axle pivot mounted. Automatic oscillation lockouts permit oscillation only with boom centred over front.

Tyres

4 tyres, 29.5 x 25 - 28 PR earthmover type.

Steering

Front, full hydraulic steering wheel controlled. Separate steering of the rear axle for rear, crab and coordinated steering.

Brakes

Service brake: pneumatic dual circuit, acting on all wheels. Parking brake: spring-applied, air released on front and rear axles.

Electrical system

24 V (Two 12 V maintenance free batteries).

*Optional equipment.

4 tyres, 29.5 R25 Michelin radials.

Caterpillar 3126 DITA diesel engine, 6 cylinders 186 kW (250 bhp) at 2500 rpm. Max. torque: 930 Nm at 1650 rpm.

Engine block heater.

Auxiliary hydraulic oil cooler.

Cross axle differential locks.

Front mounted tow winch.

Emergency steer pump.

*Further optional equipment upon request

Technische Daten: Kranoberwagen

Teleskopausleger

11,3 m bis 35,1 m vollhydraulisch teleskopierbarer 4-Stufen-Ausleger, einschliesslich serienmässiger Hilfsrollenkopf. Maximale Rollenhöhe 38,0 m.

Klappspitze

10,7 m - 18,3 m Tele-Gitterklappspitze. Abwinkelbar auf 2° oder 30°. Maximale Rollenhöhe 56,0 m.

Wippwerk

1 Hubzylinder mit Sicherheitsventil, Auslegerwinkel -3° bis 78°.

Lastmomentbegrenzer und Hubendabschaltesystem

Lastmomentbegrenzer und Hubendabschaltesystem mit audio-visueller Warneinrichtung und Bedienebelabschaltung. Diese Systeme bieten eine elektronische Anzeige von Auslegerwinkel, Auslegerlänge, Ausladung, Rollenhöhe, relative Last, maximal zulässige Last, tatsächliche Last sowie eine Hubende-Warneinrichtung.

Kabine

Verzinkte, schallgedämmte Stahlkabine, aufklappbares Dachfenster mit elektrischem Scheibenwischer, Komfortsitz mit in die Armlehnen integrierten Bedienebeln, Hydraulikölheizung. Ergonomisch angeordnete Bedienelemente und Kranbedienebel. Fahr- und Lenkbedienung.

Drehwerk

360° rundum kontinuierlich schwenkbar, Planetenschwenkwerk mit Fusspedalschwenkbremse. Hydraulisch lösbare Federspeicher-Feststellbremse und mechanische, in 1 Stellung verriegelbare Bolzenverriegelung sowie von der Kabine aus bedienbare mechanische 360°-Schwenkwerkverriegelung.

Gegengewicht

4310 Kg abnehmbares Gegengewicht sowie ein Zusatzgewicht anstelle der Hilfswinde.

Hydrauliksystem

7 Hauptzahnradpumpen mit einer Gesamtfördermenge von 754 l/Min. Filter mit Vollstrom-Überströmventil im Rücklauf. Abgesetzt montierter, thermostatisch geregelter Ölkühler und Druckkontrollanschlüsse. Tankfassungsvermögen: 757 l.

Steuerung

Stufenlose Bedienung aller Kranbewegungen mittels hydraulischer Einachs-Bedienebel mit automatischer Rückführung in die Nullstellung.

Hubwerk

Haupt- und Hilfswinde, jede mit zwei Lamellenmotoren, Planetengetriebe, zwei Geschwindigkeitsstufen mit automatischer Federspeicher-Lamellenbremse. Gerillte Seiltrommel, Windentrommel-Kabelführung und elektronische Umdrehungsanzeige.

* Zusatzausüstung

11,3 - 27,1 m vollhydraulisch teleskopierbarer 3-Stufen-Ausleger.
10,7 m Gitterklappspitze (abwinkelbar 2°, 30°).
Gegengewicht-Abbausystem.
Auslegerdämpfungssystem.
Abgesetztes Schmiersystem für das Drehgestell.
Klimaanlage.
Propangasheizung.
Zweiachs-Bedienebel.
LMB (Lastmomentbegrenzer) Leuchtbalkenanzeige.

Technische Daten: Kranunterwagen

Rahmen

2-Achsen-Spezial-Unterwagenrahmen, vollverschweißte, verwindungsfeste Kastenprofil-Konstruktion aus hochfestem Stahl. Integrierte Schlepp- und Verstauesen.

Abstützung

4 hydraulisch teleskopierbare Abstützbalken mit innengeführten Stützzyllindern und 610 mm (Durchmesser) Abstützstellern. Unabhängige Bedienung der horizontalen und vertikalen Bewegungen von der Krankabine aus. Teil-Auslage in 3 Stellungen verbolzbar. Nivellierlibelle. Maximale Stützstellerlast: 41992 Kg.

Motor

Cummins 6CTA8.3L, wassergekühlter 6-Zylinder-Turbodieselmotor mit Sekundärkühler. 186 KW (250 PS) bei 2200 U/Min. Max. Drehmoment: 1077 Nm bei 1500 U/Min. Fassungsvermögen Treibstofftank: 303 l. Abgasemission: EUROMOT / EPA / CARB (nicht Strasse).

Getriebe

Clarc Powershiftautomatikgetriebe Serie 32000, 6 Vorwärtsgänge und 6 Rückwärtsgänge.

Antrieb/Lenkung

4 x 4 x 4

Achsen

Zwei Achsen angetrieben und lenkbar. Hinterachse für 4 x 2 Fahrt abschaltbar.

Federung

Vorderachse starr am Unterwagenrahmen montiert. Hinterachse als Pendelachse montiert. Die automatische Federungsverriegelung entriegelt die Federung nur dann, wenn der Ausleger nach vorn eingemittelt ist.

Bereifung

4 Reifen, 29.5 x 25 - 28 PR Radladerreifen.

Lenkung

Vorn vollhydraulische Lenkung mittels Lenkrad. Separate Lenkung der Hinterachse für hintere Lenkung, Hundegang oder koordinierte Lenkung.

Bremsen

Betriebsbremse: Zweikreis-Druckluft-Bremssystem, auf alle Räder wirkend.
Feststellbremse: Pneumatisch lösbare Federspeicher-Feststellbremse an der Vorder- und Hinterachse.

Elektrische Anlage

24 V (Zwei 12 V wartungsfreie Batterien).

* Zusatzausüstung

4 Reifen, 29.5 R25 Michelin Radialreifen.
Caterpillar 3126 DITA Dieselmotor, 6-Zylinder 186 KW (250 PS) bei 2500 U/Min. Max. Drehmoment: 930 Nm bei 1650 U/Min.
Motorblock-Heizung.
Zusätzlicher Hydraulikölkühler.
Querdifferentialsperren.
Frontmontierte Schleppwinde.
Notlenkpumpe.

*Weitere Zusatzausrüstungen auf Anfrage

Caractéristiques de la superstructure

Flèche

Flèche quatre éléments de 11,3 m à 35,1 m à télescopage hydraulique, y compris tête de flèche auxiliaire standard. Hauteur max. de tête de flèche 38,0 m.

Extension treillis

Extension treillis télescopique de 10,7 m à 18,3 m. Inclinable à 2° ou 30°. Hauteur max. de tête de flèche 56,0 m.

Relevage

1 vérin avec clapet anti-retour, angle de flèche de -3° à + 78°.

Contrôleur d'état de charge et dispositif de fin de course haute

Contrôleur d'état de charge et dispositif de fin de course haute avec alarme sonore et visuelle et dispositif de coupure des mouvements. Ces dispositifs électroniques affichent les indications d'angle et de longueur de flèche, de portée, de hauteur de tête de flèche, de moment relatif, de charge maximum admissible, de charge levée et d'approche de bloc à bloc.

Cabine

Cabine en tôle galvanisée, insonorisée, avec baie de toit ouvrante et essuie glace électrique, siège capitonné avec commandes de grue montées sur les accoudoirs, chauffage à huile hydraulique. Instrumentation et commandes de grue disposées suivant études ergonomiques. Commandes de conduite pour le déplacement et la direction du porteur.

Orientation

Orientation continue sur 360° avec réducteur à planétaires « glide swing » et frein au pied. Frein d'immobilisation à serrage par ressorts et desserrage hydraulique. Axe de verrouillage d'orientation en position route et dispositif de verrouillage mécanique 360° commandés depuis la cabine.

Contrepoids

Contrepoids déposable de 4.310 kg plus plaque amovible en lieu de treuil auxiliaire.

Circuit hydraulique

7 pompes principales à engrenages ayant un débit total de 754 l/min. Filtration sur circuit retour avec by-pass. Refroidisseur d'huile hydraulique à commande thermostatique monté à distance et panneau de prises de pressions centralisées. Capacité du réservoir : 757 l.

Commandes de grue

Commandes progressives par leviers simple axe et retour au neutre automatique.

Treuil

Treuil de levage principal et auxiliaire, équipés de deux moteurs à palettes chacun, et réducteurs à planétaires à deux vitesses. Frein automatique à serrage par ressorts et desserrage hydraulique. Tambour de treuil rainuré, rouleau presse câble et indicateur électronique de rotation du tambour.

*Equipements optionnels

Flèche trois éléments de 11,3 à 27,1 m, à télescopage entièrement hydraulique.

Extension treillis de 10,7 m (inclinable à 2°, 30°).

Système de dépose de contrepoids.

Amortisseur sur vérin de relevage pour déplacements en position route.

Système de graissage à distance pour tourelle.

Climatisation.

Chauffage de cabine au propane.

Manipulateurs de commande « en croix ».

Barre de répétition d'affichage de moment C.E.C.

Caractéristiques du porteur

Châssis porteur

Châssis caissonné, mécanosoudé, spécifique, 2 essieux, en tôles d'acier à haute limite élastique, avec oreilles de remorquage et d'arrimage intégrées.

Calage

4 poutres à télescopage hydraulique avec vérins verticaux en position « inversée » et semelles d'appui de 610 mm de diamètre. Commande indépendante des mouvements de sortie de poutres et de vérins depuis le poste de pilotage. Trois configurations de calage sont autorisées, 0 - 50 et 100%. Niveau à bulle. Charge maximum sur les appuis: 41.992 kg.

Moteur

Moteur Diesel Cummins 6CTA8.3L, 6 cylindres, à refroidissement liquide et dispositifs de suralimentation. 186 kW (250 CV) à 2200 tr/min.

Couple max.: 1077 Nm à 1500 tr/min. Capacité du réservoir de carburant : 303 l.

Emissions de gaz polluants: EUROMOT / EPA CARB (normes chantier).

Boîte de vitesses

Boîte de vitesses Clark 32000, 6 rapports de marche avant et 6 rapports de marche arrière.

Direction/Déplacement

4 x 4 x 4

Ponts

2 ponts moto-directeurs. Pont arrière débrayable pour déplacements sur route.

Suspension

Pont avant rigide fixé au châssis. Pont arrière articulé. Le dispositif automatique de verrouillage d'articulation libère la suspension lorsque la flèche est centrée sur l'avant.

Pneumatiques

4 pneumatiques 29.5 x 25 - 28 PR de type chantier

Direction

Direction avant hydraulique commandée par volant. Direction indépendante pour les roues arrière donnant les configurations : direction arrière, marche en crabe et direction coordonnée.

Freins

Frein de service: double circuit pneumatique agissant sur toutes les roues. Frein de stationnement: à serrage par ressorts et desserrage pneumatique sur essieux avant et arrière.

Circuit électrique

12 V (Deux batteries 12 V sans entretien).

*Equipements optionnels

4 pneus, 29.5 R25 Michelin radiaux.

Moteur Diesel Caterpillar 3126 DITA, 6 cylindres 186 kW (250 bhp) à 2500 tr/min. Couple maxi 930 Nm à 1650 tr/min.

Réchauffage du bloc-moteur.

Refroidisseur d'huile hydraulique auxiliaire.

Blocage de différentiels inter roues

Treuil de halage monté à l'avant.

Pompe de direction de secours.

*Autres équipements optionnels sur demande

Especificación de la Superestructura

Pluma

De 11,3 m. hasta 35,1 m., en 4 tramos, de telescopaje totalmente hidráulico, incluyendo cabeza auxiliar de pluma tipo nariz. Altura máxima en punta 38,0 m.

Plumín

De 10,7 a 18,3 m. de celosía, plegable en un lateral de la pluma. Angulable a 2° ó 30°. Altura máxima en punta 56,0 m.

Elevación de pluma

Un cilindro con válvulas de seguridad. Angulo de pluma de -3° hasta 78°.

Sistema Indicador del Momento de Carga y de Final de Carrera del Gancho

Indicador del momento de carga y de final de carrera del gancho con alarma audiovisual y bloqueo automático de las palancas de control. Estos sistemas proporcionan información en la pantalla del ángulo de pluma, longitud, radios altura, momento de carga relativo, carga máxima permitida, indicador de cargas y alarma de final de carrera del gancho.

Cabina

De acero galvanizado, tratada acústicamente, ventana superior abatible con limpia-parabrisas eléctrico, asiento de lujo con controles de operación de la grúa e instrumentación ergonómicamente situadas, calefacción por aceite hidráulico. Controles de traslación/dirección.

Giro

Continuo a 360°, giro deslizante con planetarios y freno actuado por pedal. Freno de aparcamiento aplicado por muelle con desconexión hidráulica y pistón, bloqueo mecánico en 1 posición y bloqueo mecánico de giro en los 360° accionado desde la cabina.

Contrapeso

De 4.310 kg. desmontable, más una placa en lugar del cabrestante auxiliar.

Sistema hidráulico

Siete bombas principales de engranaje con una capacidad combinada de 754 litros/minuto. Filtro en la línea de retorno con protección by-pass. Radiador de refrigeración de aceite con control por termostato y sistema de comprobación de presión en el panel. Capacidad del depósito: 757 litros.

Sistema de Control

Controles continuos de todos los movimientos de la grúa, usando palancas de control con retorno automático a cero.

Cabrestantes

Principal y auxiliar, con motores de paletas ambos, engranajes planetarios, dos velocidades con freno automático por muelle multi-disco. Tambor acanalado, ordenador de cable en el cabrestante e indicador electrónico de dirección.

*Equipos Opcionales

Pluma de 11,3-25,6 m. en 3 secciones de telescopaje totalmente hidráulico.

Plumín de celosía de 10,7 m., plegable en un lateral de la pluma (angulable 2° y 30°).

Sistema de desmontaje del contrapeso.

Sistema de deslizamiento a alta velocidad.

Sistema remoto de engrase para el sistema de giro.

Aire acondicionado.

Calefacción de propano.

Palancas de control de doble eje.

Tubo de iluminación del Indicador de Cargas.

Especificación del Chasis

Bastidor

Chasis especial de dos ejes de construcción soldada tipo cajón resistente a la torsión, en acero de alta resistencia. Gancho de arrastre y orejetas de amarre.

Estabilizadores

4 vigas telescópicas hidráulicas con cilindros verticales invertidos y placas de apoyo cuadradas de 610 mm. de superficie. Controles independientes para los movimientos horizontales y verticales desde la cabina del operador. Tres posiciones de aplicación. Manómetro indicador de nivel. Carga máxima en cada placa de apoyo 41.992 kg.

Motor

Diesel Cummins 6CTA8.3L, 6 cilindros, refrigerado por agua, turboalimentado, 186 Kw (250 bhp) a 2.200 rpm. Par máximo: 1077 Nm a 1.500 rpm. Depósito de combustible: 303 litros. Emisión de gases: EUROMOT/EPA/CARB (non-road).

Transmisión

Clark powershift serie 32000, 6 velocidades adelante y 6 atrás.

Tracción/Dirección

4 x 4 x 4

Ejes

2 motrices y directrices. Eje trasero desconectable para desplazamiento 4x2.

Suspensión

Montaje rígido al bastidor en el eje delantero. En el eje trasero pivotante. Bloqueo automático de oscilación únicamente con la pluma centrada en la parte frontal.

Neumáticos

4 de 29.5x25-28 lonas, tipo movimiento de tierras.

Dirección

Delantera, completamente hidráulica con control por volante. Control independiente del eje trasero para dirección trasera, tipo cangrejo y coordinada.

Frenos

De Servicio: Neumáticos de doble circuito, actuando sobre todas las ruedas.

De Aparcamiento: Aplicado por muelle con desconexión neumática sobre los ejes delantero y trasero.

Sistema Eléctrico

24 V (dos baterías de 12 V sin mantenimiento).

*Equipos Opcionales

4 neumáticos 29.5 R25 Michelin, radiales.

Motor diesel Caterpillar 3126 DITA, 6 cilindros, 186 Kw (250 bhp) a 2.500 rpm. Par máximo: 930 Nm a 1.650 rpm.

Calentamiento del bloque motor.

Bloqueos cruzados del diferencial.

Cabrestante de arrastre, frontal.

Bomba auxiliar de emergencia.

*Otros opcionales a petición

Notes referring to load charts

Hinweise für Traglasttabellen

Notes relatives aux tableaux des charges

Notas para las tablas de cargas

Lifting capacities according to BS/DIN • 85%

WARNING: THIS CHART IS ONLY A GUIDE. The Notes below are for illustration only and should not be relied upon to operate the crane.

The individual crane's load chart, operating instructions and other instruction plates must be read and understood prior to operating the crane.

BS/DIN: Capacities are in accordance with DIN 15019: Part 2: 1979 and clause 9 - Stability of BS 1757: 1986.

85%: Capacities are in accordance with SAE J1063 and do not exceed 85% of the tipping load (75% for outriggers 0% extended) as determined by SAE J765.

Lifting capacities at 85% do **not** comply with the essential health and safety requirements of the EU Machinery Directive.

1. Capacities given do not include the weight of hookblocks, slings, auxiliary lifting equipment and load handling devices. Their weights **MUST** be added to the load to be lifted. When more than minimum required reeving is used, the additional rope weight shall be considered part of the load.
2. All capacities are for crane on firm, level surface. It may be necessary to have structural supports under the outrigger floats or tyres to spread the load to a larger bearing surface.
3. When either boom length or radius or both are between values listed, the smallest load shown at either the next larger radius or boom length shall be used.
4. For outrigger operation, **ALL** outriggers shall be fully extended with tyres raised free of ground before raising the boom or lifting loads.
5. Tyres shall be inflated to the recommended pressure before lifting on rubber.

Traglasten entsprechen BS/DIN • 85%

WARNUNG: DIESE TABELLE IST LEDIGLICHE EINE RICHTLINIE. Die Hinweise dienen als Erklärung und sind für die Kranbedienung nicht maßgebend. Vor Inbetriebnahme des Kranes sind Traglasttabellen, Bedienungsanleitung und andere Vorschriften eingehend zu studieren.

BS/DIN: Die Tragkraftwerte entsprechen DIN 15019 Teil 2, 1979 und der Klausel 9 - Stabilität von BS 1757, 1986.

85%: Tragkraftwerte entsprechen SAE J1063 und überschreiten nicht 85 % der Kipplast (75% bei ganz ausgefahrener Abstützung) gemäß Richtlinien SAE J 765.

Die 85% Traglasten entsprechen **nicht** den Sicherheitsanforderungen der EG-Maschinen-richtlinie.

1. Das Gewicht der Hakenflaschen und aller Anschlagmittel muß zu der Last hinzugerechnet werden. Beim Einscheren mit erhöhten Werten ist das zusätzliche Seilgewicht als Teil der Last zu betrachten.
2. Alle Werte gelten für den Kran auf festem, ebenem Untergrund. Eventuell müssen die Stützteller oder Reifen unterlegt werden, um die Last über eine größere Abstützfläche zu verteilen.
3. Wenn Auslegerlänge oder Radius oder beide Werte zwischen den aufgeführten Werten liegen, ist die geringere der Traglasten zu wählen, die für den die nächstgrößere Ausladung oder die nächste bzw. anschließende Auslegerlänge genannt sind.
4. In abgestütztem Zustand müssen **ALLE** Stützen komplette ausgefahren sein. Die Reifen dürfen den Boden nicht berühren. Erst danach dürfen Lasten oder der Ausleger angehoben werden.
5. Bevor frei auf Rädern gearbeitet wird, müssen, die Reifen mit dem vorschriftsmäßigen Druck aufgefüllt werden.

Capacités de levage selon BS/DIN • 85%

ATTENTION: CE TABLEAU N'EST QU'UN GUIDE. Les notes ci-dessous sont données à titre d'exemple et ne devront pas être utilisées pour faire fonctionner la grue. Toute la documentation concernant chaque type de grue: tableau des charges, instructions de fonctionnement et toutes autres plaques d'instructions devront être lues et comprises avant de manoeuvrer la grue.

BS/DIN: Les capacités de levage sont conformes à la norme DIN 15019 section 2 de 1979 et à la clause 9 - stabilité - de la norme BS1757: 1986.

85%: Les capacités de levage sont conformes à la norme SAE J1063 et ne dépassent pas 85% de la charge de basculement (75% pour les poutres de calage déployées à 0%) tel que cela est prescrit par la norme SAE J765. Les capacités de levage à 85% **ne** respectent pas les préconisations concernant la santé et la sécurité prévues par la Directive Machines CE.

1. Les charges mentionnées dans les tableaux ne comprennent pas le poids des moufles, des élingues et autres accessoires de levage qui doit être additionné à celui de la charge levée. Lorsque le mouflage est supérieur au minimum requis le poids de l'excédent de câble doit être additionné à celui de la charge.
2. Les capacités sont données sur sol ferme et de niveau. Il peut être nécessaire d'utiliser des bastaings ou des accessoires similaires afin de répartir la charge transmise au sol par les roues ou les patins de calage.
3. Lorsque la longueur de flèche ou la portée ne correspond pas aux valeurs mentionnées dans les tableaux, il convient de se référer à la valeur inférieure mentionnée pour la portée ou la longueur de flèche immédiatement supérieure.
4. Pour utilisation machine calée, les traverses de calage doivent être totalement télescopées et les roues décollées du sol avant de relever la flèche ou de lever des charges.
5. Les pneumatiques devront être gonflés aux pressions préconisées avant tout levage en libre.

Capacidades de elevación de acuerdo con BS/DIN • 85%

AVISO: ESTA TABLA ES SOLO UNA ORIENTACION. Las notas que aparecen al final de la misma solo sirven de ilustración y no deben ser tomadas como instrucciones para operar la grúa. La tabla de cargas, las instrucciones de operación y otras placas ilustrativas de cada grúa deben ser leídas y correctamente interpretadas antes de operar la grúa.

BS/DIN: Capacidades de acuerdo con las Normas DIN 15019: Apartado 2: 1979 y cláusula 9 - Estabilidad. BS1757: 1986.

85%: Capacidades de acuerdo con las Normas SAE J1063 y no exceden del 85% del momento de vuelco (75% para las cargas sobre estabilizadores extendidos al 0%) como fijan las normas SAE J765. Las capacidades de elevación al 85% **no** cumplen con las normas de seguridad exigidas por las Directivas de Maquinaria de la CEE.

1. Las cargas indicadas no incluyen el peso de los ganchos, eslingas, equipos auxiliares y aparos de elevación. Sus pesos **DEBEN** ser añadidos al de la carga a elevar. Cuando se utilice un número de ramales de cable superior al necesario, el peso adicional del cable debe ser considerado como parte de la carga.
2. Todas las capacidades corresponden a la grúa situada sobre terreno firme nivelado y uniforme. La naturaleza del terreno puede hacer necesario colocar, bajo los apoyos de los estabilizadores o bajo los neumáticos, elementos estructurales que repartan la carga sobre una mayor superficie de apoyo.
3. Cuando se trabaje con longitudes de pluma o rádios, intermedios entre los valores reflejados en las tablas, se considerará la carga inmediata inferior indicada en el radio o longitud de pluma inmediato superior.
4. Para trabajos sobre estabilizadores, **TODOS** los estabilizadores estarán totalmente extendidos y los neumáticos sin tocar el suelo antes de elevar pluma o izar cargas.
5. Los neumáticos deberán estar inflados a la presión recomendada antes de elevar cargas sobre neumáticos.

Lifting capacities for telescopic boom
Traglasten am Teleskopausleger
Capacités de levage à la flèche télescopique
Capacidades de elevación con pluma telescópico



11.3 – 35.1 m



100%



360°



4,310 kg



BS/DIN

m	11.3	13.7	16.8	19.8	22.9	25.9	29.0	32.0	35.1
3.0	55,000	39,200	34,250						
3.5	45,625	39,200	34,250	27,625					
4.0	42,100	39,200	34,250	27,625					
4.5	39,575	37,125	33,075	27,625	20,000				
5.0	37,115	34,700	31,175	27,500	20,000				
6.0	31,775	30,600	27,050	24,250	18,825	18,525	16,675		
7.0	26,825	26,300	23,925	21,275	17,000	16,500	15,150	13,500	11,075
8.0	22,300	21,850	21,375	18,950	15,325	15,275	13,900	12,200	10,850
9.0	15,275	18,600	18,175	17,075	14,000	14,000	12,575	10,850	10,100
10.0		15,000	15,525	15,250	13,075	12,925	11,725	9,985	9,400
12.0			11,450	11,250	11,000	10,800	9,930	8,600	7,900
14.0			8,120	8,000	8,910	9,120	8,685	7,560	6,930
16.0				5,790	6,395	6,890	7,185	6,750	6,165
18.0					4,820	5,280	5,560	5,640	5,090
20.0					3,655	4,065	4,335	4,600	4,590
22.0						3,115	3,375	3,635	3,885
24.0							2,610	2,855	3,100
26.0							2,005	2,235	2,455
28.0								1,710	1,920
30.0									1,460
32.0									1,070

A6-829-012762



85%

m	11.3	13.7	16.8	19.8	22.9	25.9	29.0	32.0	35.1
3.0	55,000	39,200	34,250						
3.5	45,625	39,200	34,250	27,625					
4.0	42,100	39,200	34,250	27,625					
4.5	39,575	37,125	34,250	27,625	20,000				
5.0	37,115	34,700	33,375	27,625	20,000				
6.0	31,775	30,600	29,025	26,950	20,000	19,700	18,325		
7.0	27,750	27,300	25,750	24,150	19,400	18,025	16,650	13,875	11,075
8.0	23,325	22,950	22,675	21,300	17,550	15,975	14,975	13,475	10,850
9.0	15,275	19,450	19,200	19,050	16,000	14,525	13,550	12,550	10,175
10.0		16,725	16,475	16,325	14,650	13,300	12,350	11,625	9,490
12.0			12,500	12,350	12,475	11,275	10,425	9,830	8,185
14.0			9,180	9,065	9,675	9,705	8,950	8,400	7,140
16.0				6,720	7,315	7,810	7,770	7,270	6,300
18.0					5,640	6,100	6,370	6,350	5,665
20.0					4,405	4,805	5,070	5,330	5,095
22.0						3,795	4,050	4,300	4,555
24.0							3,235	3,475	3,720
26.0							2,595	2,815	3,035
28.0								2,260	2,465
30.0									1,975
32.0									1,560

A6-829-011938C

Lifting capacities for telescopic boom
Traglasten am Teleskopausleger
Capacités de levage à la flèche télescopique
Capacidades de elevación con pluma telescópico



11.3 – 35.1 m



50%



360°



4,310 kg



BS/DIN

m	11.3	13.7	16.8	19.8	22.9	25.9	29.0	32.0	35.1
3.0	50,000	39,200	34,250						
3.5	45,625	39,200	34,250	27,625					
4.0	42,100	39,200	34,250	27,625					
4.5	39,575	37,125	33,075	27,625	20,000				
5.0	36,950	34,700	31,175	27,500	20,000				
6.0	28,200	26,500	24,750	23,575	18,825	18,525	16,675		
7.0	20,450	20,300	19,225	18,375	17,000	16,500	15,150	13,500	11,075
8.0	15,575	15,475	15,350	14,750	14,900	14,875	13,900	12,200	10,850
9.0	12,650	12,150	12,075	12,000	12,350	12,425	12,425	10,850	10,100
10.0		9,790	9,715	9,655	10,300	10,525	10,575	9,985	9,400
12.0			6,485	6,440	7,050	7,550	7,895	7,970	7,900
14.0			4,400	4,355	4,930	5,400	5,750	6,100	6,220
16.0				2,895	3,445	3,895	4,220	4,545	4,815
18.0					2,365	2,780	3,090	3,390	3,690
20.0					1,555	1,925	2,220	2,505	2,790
22.0						1,245	1,525	1,805	2,075
24.0							965	1,235	1,495
26.0								765	1,015
28.0									610

A6-829-012763



85%

m	11.3	13.7	16.8	19.8	22.9	25.9	29.0	32.0	35.1
3.0	50,000	39,200	34,250						
3.5	45,625	39,200	34,250	27,625					
4.0	42,100	39,200	34,250	27,625					
4.5	39,575	37,125	34,250	27,625	20,000				
5.0	36,950	34,700	33,375	27,625	20,000				
6.0	28,300	26,500	24,750	23,575	20,000	19,700	18,325		
7.0	21,925	20,525	19,225	18,375	18,325	18,025	16,650	13,875	11,075
8.0	17,050	16,475	15,425	14,750	14,900	14,875	14,800	13,475	10,850
9.0	13,500	13,450	12,650	12,075	12,350	12,425	12,425	12,375	10,175
10.0		10,925	10,525	10,050	10,375	10,525	10,575	10,575	9,490
12.0			7,445	7,135	7,555	7,765	7,895	7,970	8,005
14.0			5,225	5,155	5,615	5,860	6,030	6,145	6,220
16.0				3,645	4,180	4,470	4,660	4,800	4,890
18.0					3,035	3,410	3,615	3,765	3,880
20.0					2,175	2,535	2,790	2,955	3,075
22.0						1,815	2,085	2,290	2,420
24.0							1,490	1,745	1,875
26.0							1,005	1,255	1,425
28.0								825	1,035
30.0									705

A6-829-011939C

Lifting capacities for telescopic boom
Traglasten am Teleskopausleger
Capacités de levage à la flèche télescopique
Capacidades de elevación con pluma telescópico



11.3 – 35.1 m



0%



360°



4,310 kg



BS/DIN

m	11.3	13.7	16.8	19.8	22.9	25.9	29.0	32.0	35.1
3.0	37,600	34,550	31,450						
3.5	30,525	28,250	25,925	22,900					
4.0	25,025	23,250	21,450	20,225					
4.5	21,025	19,575	18,100	17,125	16,525				
5.0	17,950	16,725	15,500	14,675	14,625				
6.0	13,150	12,650	11,725	11,100	11,275	11,000	10,950		
7.0	9,820	9,590	9,125	8,625	8,905	9,000	9,020	7,935	7,915
8.0	7,515	7,355	7,115	6,785	7,140	7,295	7,375	7,405	7,390
9.0	5,760	5,615	5,445	5,320	5,775	5,975	6,095	6,160	6,190
10.0		4,350	4,200	4,090	4,635	4,915	5,065	5,160	5,215
12.0			2,430	2,335	2,840	3,260	3,515	3,645	3,740
14.0			1,230	1,145	1,625	2,020	2,260	2,495	2,670
16.0					745	1,120	1,345	1,565	1,785
18.0							660	865	1,070
20.0									570

AG-829-012785A



75%

m	11.3	13.7	16.8	19.8	22.9	25.9	29.0	32.0	35.1
3.0	37,600	34,550	31,450						
3.5	30,525	28,250	25,925	22,900					
4.0	25,025	23,250	21,450	20,225					
4.5	21,025	19,575	18,100	17,125	16,525				
5.0	17,950	16,725	15,500	14,675	14,625				
6.0	13,150	12,650	11,725	11,100	11,275	11,000	10,950		
7.0	9,820	9,590	9,125	8,625	8,905	9,000	9,020	7,935	7,915
8.0	7,515	7,355	7,160	6,785	7,140	7,295	7,375	7,405	7,390
9.0	5,835	5,725	5,595	5,370	5,775	5,975	6,095	6,160	6,190
10.0		4,540	4,425	4,250	4,690	4,915	5,065	5,160	5,215
12.0			2,765	2,585	3,065	3,330	3,515	3,645	3,740
14.0			1,640	1,410	1,915	2,195	2,405	2,555	2,670
16.0				540	1,055	1,350	1,570	1,735	1,860
18.0						690	920	1,090	1,230
20.0								575	720

AG-829-011940B

Lifting capacities for telescopic boom
Traglasten am Teleskopausleger
Capacités de levage à la flèche télescopique
Capacidades de elevación con pluma telescópico



11.3 – 29.0 m



29.5 x 25



360°/0°



4,310 kg



BS/DIN

		0 kph					< 4 kph				
m	11.3	13.7	16.8	19.2	22.9	11.3	13.7	16.8	19.2	22.9	
360°						0°					
3.0	15,075	14,250				21,325	14,550				
3.5	13,650	12,900	11,725			20,225	14,550	12,750	11,325		
4.0	12,225	11,525	11,000			19,075	14,550	12,750	11,325		
4.5	10,925	10,300	9,970			17,925	14,550	12,750	11,325	8,910	
5.0	9,765	9,140	8,945			16,875	14,550	12,750	11,325	8,910	
6.0	7,690	7,220	7,070	6,785	5,960	14,750	14,550	12,750	11,325	8,910	
7.0	5,925	5,675	5,590	5,520	4,950	12,700	12,650	12,575	11,325	8,910	
8.0	4,645	4,480	4,385	4,295	4,030	11,050	10,925	10,775	10,600	8,730	
9.0	3,730	3,550	3,360	3,205	3,270	9,020	8,800	8,550	8,350	8,255	
10.0		2,615	2,490	2,395	2,635		7,065	6,840	6,660	7,485	
12.0			1,080	1,000	1,555			4,455	4,310	5,010	
14.0					555			2,880	2,755	3,375	
16.0									1,650	2,210	
18.0										1,460	
20.0										695	

A6-829-012802A

A6-829-012803A



85%

		0 kph							< 4 kph						
m	11.3	13.7	16.8	19.2	22.9	25.9	29.0	11.3	13.7	16.8	19.2	22.9	25.9	29.0	
360°								0°							
3.0	15,075	14,250						21,325	14,550						
3.5	13,650	12,900	11,725					20,225	14,550	12,750	11,325				
4.0	12,225	11,525	11,000					19,075	14,550	12,750	11,325				
4.5	10,925	10,300	9,970					17,925	14,550	12,750	11,325	8,910			
5.0	9,765	9,140	8,945					16,875	14,550	12,750	11,325	8,910			
6.0	7,690	7,220	7,070	6,785	5,960	5,465		14,750	14,550	12,750	11,325	8,910	7,480	5,375	
7.0	5,925	5,675	5,590	5,520	4,950	4,905	4,130	12,700	12,650	12,575	11,325	8,910	7,480	5,375	
8.0	4,645	4,480	4,385	4,295	4,030	4,305	4,130	11,050	10,925	10,800	10,700	8,730	7,480	5,375	
9.0	3,825	3,550	3,360	3,205	3,270	3,725	4,130	9,690	9,545	9,370	9,225	8,255	7,480	5,375	
10.0		2,740	2,570	2,435	2,635	3,165	3,475		8,035	7,820	7,645	7,775	7,480	5,375	
12.0			1,305	1,160	1,625	2,100	2,215			4,580	4,465	5,045	5,530	5,375	
14.0					865	1,100	1,245			3,320	3,220	3,755	4,200	4,535	
16.0											2,250	2,750	3,170	3,485	
18.0												1,830	2,340	2,645	
20.0												1,255	1,480	1,585	
22.0													865	910	
24.0														465	

A6-829-012306A

A6-829-012307

		0 kph					
m	11.3	13.7	16.8	19.2	22.9	25.9	29.0
0° (±6°)							
3.0	20,000	17,725					
3.5	20,000	17,725	13,575	10,775			
4.0	19,775	17,725	13,575	10,775			
4.5	19,450	17,725	13,575	10,775	8,800		
5.0	18,300	16,400	13,575	10,775	8,800		
6.0	15,700	13,825	12,675	10,775	8,800	7,230	
7.0	13,475	11,750	11,000	9,725	8,800	7,230	7,030
8.0	11,550	10,050	9,555	8,615	8,360	7,095	6,850
9.0	10,025	8,660	8,270	7,595	7,300	6,810	6,320
10.0		7,470	7,130	6,655	6,360	6,080	5,800
12.0			5,190	4,965	4,760	4,775	4,795
14.0			3,610	3,500	3,460	3,645	3,830
16.0				2,220	2,375	2,640	2,905
18.0					1,460	1,735	2,015
20.0						675	915

A6-829-012305A

0° = over front, über Vorderkante, sur avant, por la parte frontal

Lifting capacities for telescopic boom
Traglasten am Teleskopausleger
Capacités de levage à la flèche télescopique
Capacidades de elevación con pluma telescópico



11.3 – 29.0 m



29.5 R25



360°/0°



4,310 kg



BS/DIN

m	0 kph					< 4 kph				
	11.3	13.7	16.8	19.2	22.9	11.3	13.7	16.8	19.2	22.9
	360°					0°				
3.0	16,725	16,275				26,150	26,150			
3.5	14,750	14,375				26,150	26,150			
4.0	13,050	12,725				26,150	26,150			
4.5	11,600	11,300	10,950			26,150	26,150	26,150		
5.0	10,325	10,075	9,760			24,250	24,200	24,125		
6.0	8,230	8,030	7,775	7,580		19,825	19,625	19,400	13,550	
7.0	6,550	6,395	6,195	6,040	5,790	15,175	14,950	14,700	13,550	
8.0	5,180	5,055	4,900	4,705	5,245	11,875	11,650	11,375	11,150	
9.0	4,040	3,945	3,705	3,480	3,995	9,565	9,320	9,030	8,805	9,440
10.0		2,960	2,720	2,535	3,030		7,505	7,250	7,045	7,645
12.0			1,320	1,170	1,635			4,770	4,605	5,150
14.0								3,130	2,990	3,495
16.0									1,840	2,325
18.0										1,475
20.0										845

AG-829-012799B

AG-829-012800A



85%

m	0 kph							< 4 kph						
	11.3	13.7	16.8	19.2	22.9	25.9	29.0	11.3	13.7	16.8	19.2	22.9	25.9	29.0
	360°							0°						
3.0	22,675	22,675						26,150	26,150					
3.5	21,775	21,225						26,150	26,150					
4.0	19,750	19,350						26,150	26,150					
4.5	16,825	16,700	16,050					26,150	26,150	26,150				
5.0	14,100	13,950	13,775					24,250	24,200	24,125				
6.0	10,375	10,200	9,990	9,480				19,825	19,625	19,400	13,550			
7.0	7,965	7,765	7,515	7,320	6,665	7,120		16,325	16,125	15,875	13,550			
8.0	6,260	6,045	5,780	5,565	6,095	6,535		13,125	12,900	12,625	12,425			
9.0	4,990	4,765	4,485	4,265	4,765	5,180	5,395	10,500	10,425	10,125	9,920	10,200	10,700	8,525
10.0		3,670	3,445	3,260	3,740	4,135	4,350		8,500	8,255	8,055	8,640	9,130	8,525
12.0			1,955	1,810	2,155	2,155	2,155		5,620	5,460	5,990	6,430	6,875	
14.0									3,875	3,745	4,235	4,645	5,055	
16.0										2,460	2,990	3,375	3,760	
18.0											1,980	2,440	2,795	
20.0											1,150	1,595	2,045	
22.0												940	1,375	
24.0														715

AG-829-011942B

AG-829-011943B

m	0 kph						
	11.3	13.7	16.8	19.2	22.9	25.9	29.0
	0° (±6°)						
3.0	22,675	22,675					
3.5	22,675	22,675					
4.0	21,400	21,400					
4.5	19,400	19,400	19,400				
5.0	18,100	18,100	18,100				
6.0	15,450	15,450	15,450	12,350			
7.0	13,800	13,350	12,775	12,350	9,090	8,525	
8.0	12,125	11,875	11,550	11,325	9,090	8,525	
9.0	10,425	9,870	9,150	8,600	9,090	8,525	7,030
10.0		8,500	8,255	7,530	8,240	7,785	6,495
12.0			5,620	5,460	5,990	6,320	5,340
14.0			3,875	3,745	4,235	4,645	4,325
16.0			2,460	2,990	3,375	3,430	
18.0				1,980	2,440	2,635	
20.0					1,150	1,595	1,920
22.0						940	1,275
24.0							695

AG-829-011941B

0° = over front, über Vorderkante, sur avant, por la parte frontal

Lifting capacities for telescopic swingaway
Traglasten Teleskopklappspitze
Capacités de levage à l'extension télescopique
Capacidades de elevación para plumín telescópico



35.1 m



10.7 – 18.3 m



100%



360°



4,310 kg



BS/DIN

35.1				
m	10.7		18.3	
	2°	30°	2°	30°
10.0	5,390			
12.0	4,890		3,035	
14.0	4,235	3,400	2,935	
16.0	3,775	3,355	2,880	
18.0	3,315	3,255	2,820	
20.0	2,995	2,970	2,760	1,810
22.0	2,670	2,670	2,500	1,745
24.0	2,400	2,420	2,265	1,605
26.0	2,165	2,200	2,060	1,515
28.0	1,970	1,980	1,880	1,475
30.0	1,695	1,710	1,720	1,440
32.0	1,275	1,290	1,560	1,405
34.0	1,110	1,125	1,440	1,375
36.0	585	600	1,315	1,345
38.0			1,030	1,045
40.0			755	770
42.0			510	525

A6-829-012795



85%

35.1				
m	10.7		18.3	
	2°	30°	2°	30°
10.0	5,850			
12.0	5,465		3,035	
14.0	5,000	3,400	2,935	
16.0	4,600	3,355	2,880	
18.0	4,280	3,255	2,820	
20.0	3,985	3,170	2,760	1,810
22.0	3,735	3,095	2,655	1,745
24.0	3,510	3,025	2,535	1,605
26.0	3,315	2,970	2,260	1,515
28.0	2,780	2,780	2,065	1,475
30.0	2,255	2,255	1,860	1,440
32.0	1,805	1,805	1,665	1,405
34.0	1,415	1,415	1,470	1,375
36.0	1,075	1,075	1,350	1,345
38.0	770	770	1,290	1,325
40.0	505	505	1,185	1,185
42.0			925	925
44.0			685	685

A6-829-011944B

Lifting capacities for telescopic swingaway
Traglasten Teleskopklappspitze
Capacités de levage à l'extension télescopique
Capacidades de elevación para plumín telescópico



35.1 m



10.7 – 18.3 m



50%



360°



4,310 kg



BS/DIN

35.1					
m	10.7			18.3	
	2°	30°		2°	30°
10.0	5,390				
12.0	4,890			3,035	
14.0	4,235	3,400		2,935	
16.0	3,775	3,355		2,880	
18.0	3,315	3,255		2,820	
20.0	2,805	2,805		2,760	1,810
22.0	2,150	2,165		2,500	1,745
24.0	1,555	1,570		2,205	1,605
26.0	1,065	1,080		1,760	1,515
28.0	645	660		1,385	1,385
30.0				1,035	1,050
32.0				695	710

A6-829-012796



85%

35.1					
m	10.7			18.3	
	2°	30°		2°	30°
10.0	5,850				
12.0	5,465			3,035	
14.0	5,000	3,400		2,935	
16.0	4,550	3,355		2,880	
18.0	3,580	3,255		2,820	
20.0	2,805	2,805		2,760	1,810
22.0	2,175	2,175		2,655	1,745
24.0	1,645	1,645		2,205	1,605
26.0	1,200	1,200		1,760	1,515
28.0	820	820		1,385	1,385
30.0				1,055	1,055
32.0				765	765
34.0				515	515

A6-829-011945C

Lifting capacities for fixed length offsettable swingaway

Traglasten für Festlängen abwinkelbare Klappspitze

Capacités de levage sur extension treillis inclinable, non télescopique

Capacidades de elevación para plumín no telescópico, angulable



m	10.7	
	2°	30°
10.0	5,580	
12.0	5,080	
14.0	4,435	3,535
16.0	3,975	3,490
18.0	3,515	3,390
20.0	3,200	3,150
22.0	2,875	2,855
24.0	2,600	2,605
26.0	2,370	2,390
28.0	2,140	2,175
30.0	1,935	1,945
32.0	1,515	1,525
34.0	1,145	1,155
36.0	825	835
38.0	540	550

A6-829-012792



m	10.7	
	2°	30°
10.0	5,580	
12.0	5,080	
14.0	4,435	3,535
16.0	3,975	3,490
18.0	3,515	3,390
20.0	3,065	3,065
22.0	2,390	2,400
24.0	1,795	1,805
26.0	1,300	1,310
28.0	885	895
30.0	530	540

A6-829-012793

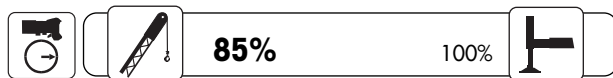

m	10.7	
	2°	30°
10.0	5,850	
12.0	5,600	
14.0	5,135	3,535
16.0	4,735	3,490
18.0	4,415	3,390
20.0	4,120	3,305
22.0	3,870	3,230
24.0	3,645	3,160
26.0	3,450	3,105
28.0	3,000	3,000
30.0	2,475	2,475
32.0	2,025	2,025
34.0	1,635	1,635
36.0	1,295	1,295
38.0	995	995
40.0	725	725

A6-829-012295

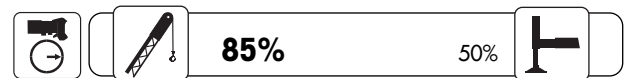

m	10.7	
	2°	30°
10.0	5,850	
12.0	5,600	
14.0	5,135	3,535
16.0	4,735	3,490
18.0	3,840	3,390
20.0	3,065	3,065
22.0	2,435	2,435
24.0	1,910	1,910
26.0	1,465	1,465
28.0	1,085	1,085
30.0	755	755

A6-829-012302A

Weight reduction for load handling devices
Gewichte der Lastaufnahmemittel
Réductions de charge pour accessoires de levage
Deducciones de peso par accesorios de elevación

Auxiliary boom nose / Zusatz-Auslegerkopf / <i>Tête de flèche auxiliaire</i> / Cabeza auxiliar	50 kg
Hookblocks / Hakenflaschen / <i>Moufles</i> / Ganchos	
55 tonne 5 sheave / Seilscheiben / <i>reas</i> / <i>poleas</i>	578 kg
13.6 tonne 1 sheave / Seilscheiben / <i>reas</i> / <i>poleas</i>	172 kg
9.1 tonne hook and weight / Einseilhaken / <i>crochet lesté</i> / gancho y bola	254 kg
10.7 m Extension / Klappspitze / <i>Prolongacion</i>	
Stowed / Seitlich angeklappt / <i>En position de transport</i> / <i>In posicion de transporte</i>	304 kg
Erected / In Arbeitsstellung / <i>En position de travail</i> / <i>Montado</i>	2,350 kg
10.7 m – 18.3 m Extension / Klappspitze / <i>Prolongacion</i>	
Stowed /Seitlich angeklappt / <i>En position de transport</i> / <i>plegada</i>	406 kg
Erected (retracted) / Arbeitsstellung (einsteleskopiert) / <i>En position de travail (retré)</i> / <i>montada (recogido)</i>	3,085 kg
Erected (extended) / Arbeitsstellung (austeleskopiert) / <i>En position de travail (deployé)</i> / <i>montada (extendido)</i>	4,187 kg

NOTE:

All load handling devices and boom attachments are considered part of the load and suitable allowances must be made for their combined weights.

HINWEIS:

Alle Lastaufnahmemittel und jede Zusatzausrüstung des Hauptauslegers werden als Teil der Traglast betrachtet und ihre kombinierten Gewichte müssen beim Feststellen der Nettolast entsprechend berücksichtigt (abgezogen) werden.

REMARQUE:

Les équipements complémentaires et accessoires de levage sont considérés comme faisant partie de la charge; les réductions de charges de leurs poids combinés doivent être effectuées.

NOTA:

Todos los aparejos de elevacion e implementos de pluma son considerados parte de la carga y deben ser tenidos en cuenta para calcular los pesos a elevar.

Symbols Glossary
Symbolerklärungs
Glossaire des symboles
Glosario de símbolos

Notes
Hinweise
Notes
Notas

	Axle load Achslast Charge à l'essieu Carga por eje		Auxiliary hoist Hilfshubwerk Treuil auxiliaire Cabrestante auxiliar
	Boom Ausleger Flèche Pluma		Hookblock Hakenflasche Moufle Gancho
	Boom elevation Wippwerk Relevage Elevacion de pluma		Lattice extension Gitterspitze Extension treillis Extensión de celosía
	Boom telescoping Teleskopieren Télescopage de flèche Telescopaje de pluma		Outriggers Abstützung Calage Estabilizadores
	Counterweight Gegengewicht Contrepoids Contrapeso		Radius Ausladung Portée Radio
	Crane functions Kranbewegungen Mouvements de la grue Funciones de la grúa		Slewing/Working range Drehwerk/Arbeitsbereich Orientation/Rayon d'operation Giro/Gamma de trabajo
	Crane travel Fahrstellung Déplacement de la grue Grúa en traslado		Travel speed Fahrgeschwindigkeit Vitesse de déplacement Velocidad de desplazamiento
	Free on wheels Freistehend Sur pneus Sobre neumáticos		Speed Geschwindigkeit Vitesse Velocidad
	Gear Gang Rapport Cambio		Low range Kleinste Übersetzung Gamme basse Marchas cortas
	Gradeability Steigfähigkeit Aptitude en pente Superacion de pendientes		Tyres Bereifung Pneumatiques Neumáticos
	Main hoist Haupthubwerk Treuil principal Cabrestante principal		

A large grid area for taking notes, consisting of a blue border and a light blue grid pattern.

Notes

Hinweise

Notes

Notas

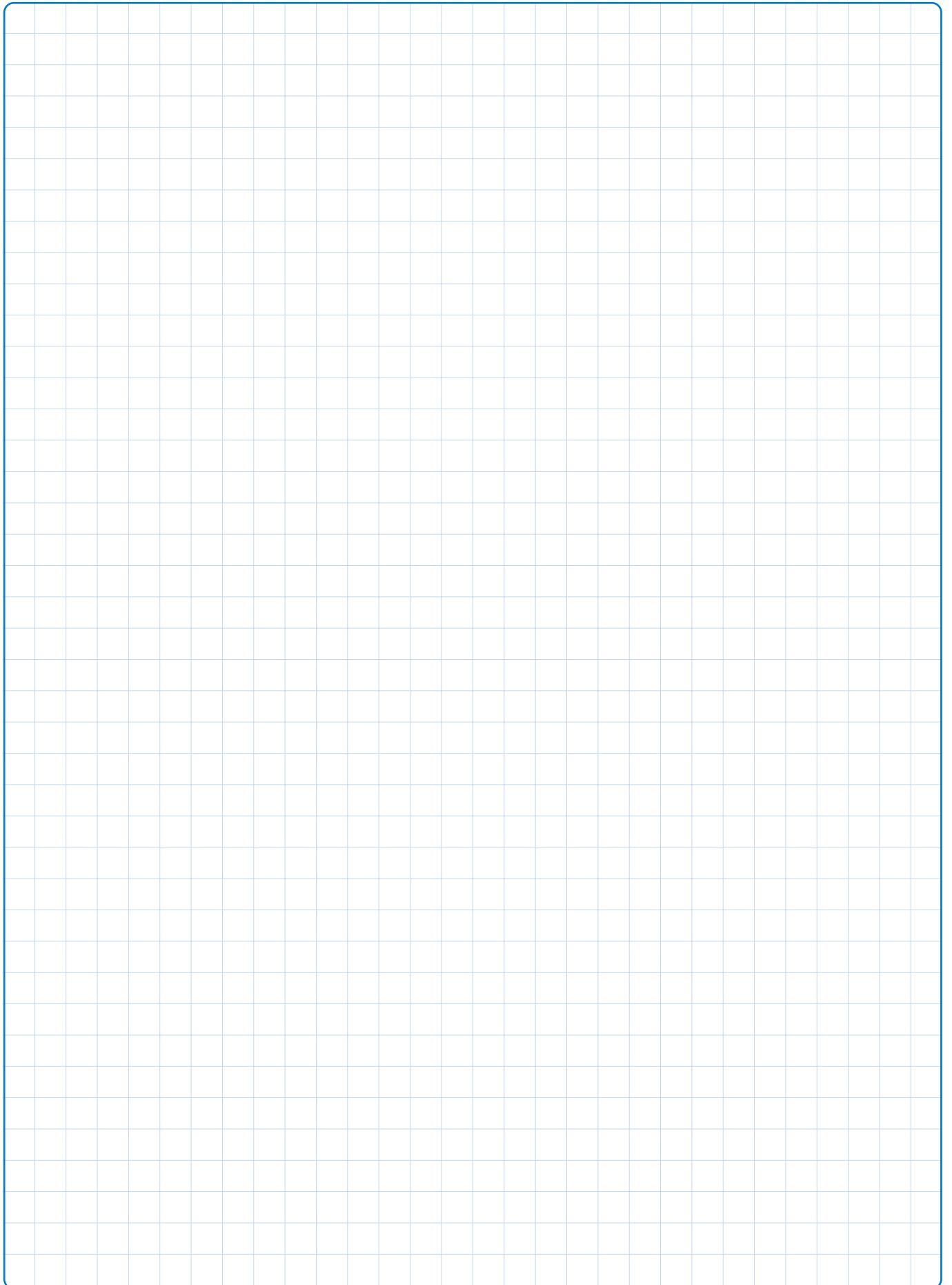

Notes

Hinweise

Notes

Notas

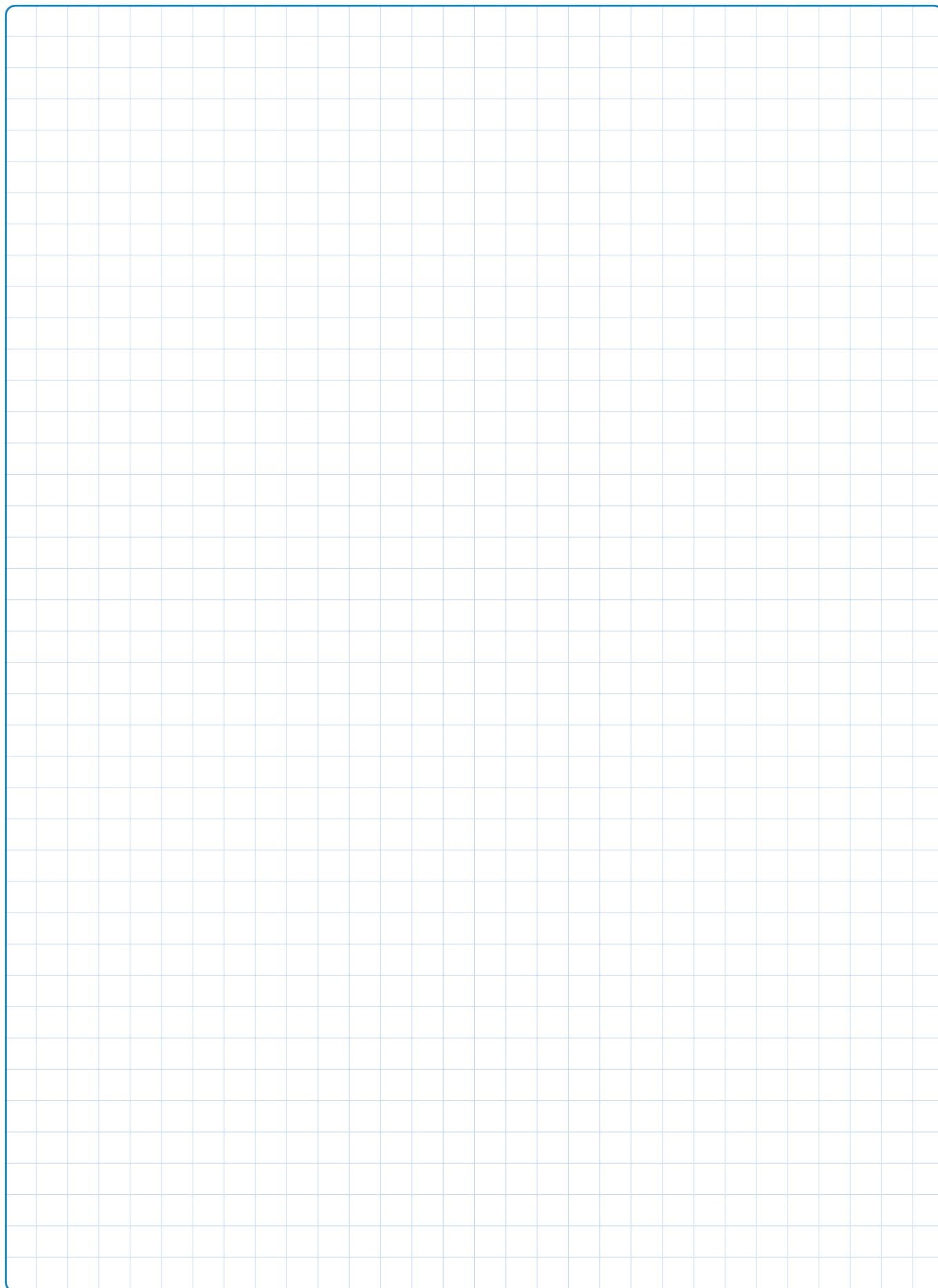

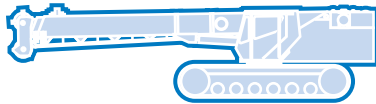
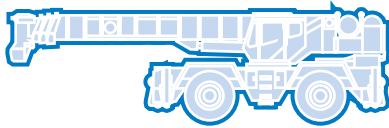
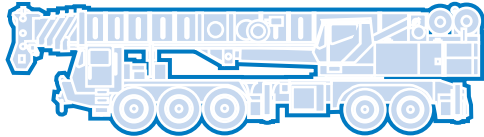
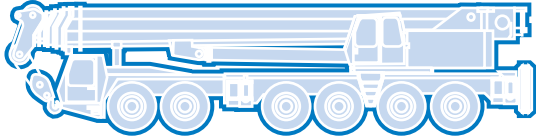
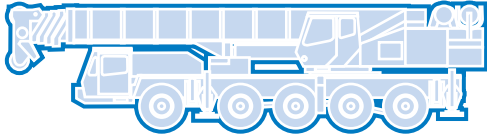

Grove Worldwide – World Headquarters

Grove U.S. L.L.C.
1565 Buchanan Trail East
P.O. Box 21
Shady Grove, Pennsylvania 17256, U.S.A.
Tel: [Int + 1] (717) 597-8121
Fax: [Int + 1] (717) 597-4062
Western Hemisphere

Grove Europe Limited*
Sunderland SR4 6TT, England
Tel: [Int + 44] 191 565-6281
Fax: [Int + 44] 191 564-0442
Europe, Africa, Middle East, Asia/Pacific

Grove Europe Limited*
Telford Road, Bicester
Oxfordshire, OX6 0TZ
Tel: [Int + 44] 1869 878-890
Fax: [Int + 44] 1869 878-891
*Grove Europe Limited, Registered in England,
Number 1845128, Registered office, Crown Works,
Pallion, Sunderland, Tyne & Wear, England SR4 6TT

**Deutsche Grove GmbH
Sales and Service**
Helmholtzstrasse 12, Postfach 5026
D-40750 Langenfeld, Germany
Tel: [Int + 49] (2173) 8909-0
Fax: [Int + 49] (2173) 8909-30

Wilhelmshaven Works
Industriegelände West, Postfach 1853
D-26358 Wilhelmshaven, Germany
Tel: [Int + 49] (4421) 294-0
Fax: [Int + 49] (4421) 294-301

Grove France S.A.
16, chaussée Jules-César, 95520 OSNY
B.P. 203, 95523 CERGY PONTOISE CEDEX
France
Tel: [Int + 33] (1) 30313150
Int: [Int + 33] (1) 30386085

Grove Asia/Pacific - Regional Office
171 Chin Swee Road
#06-01 San Centre
Singapore 0316
Tel: [Int + 65] 536-6112
Fax: [Int + 65] 536-6119
Asia/Pacific, Near East

Grove China - Representative Office
Room 713, Towercrest Plaza
No. 3 Mai Zi Dian West Road
Chao Yang District
Beijing, China 100016
Tel: [Int + 86] (10) 64 67 16 90
Fax: [Int + 86] (10) 64 67 16 91

Grove Product Support
Western Hemisphere
1086 Wayne Avenue
Chambersburg, Pennsylvania USA
Tel: [Int + 1] (717) 263-5100
Fax: [Int + 1] (717) 267-0404

Europe, Africa, Middle East, Asia/Pacific
Sunderland SR4 6TT, England
Tel: [Int + 44] 191 565-6281
Parts Fax: [Int + 44] 191 510-9242
Service Fax: [Int + 44] 191 510-9560

<http://www.grovetworldwide.com>

Constant improvement and engineering progress make it necessary that we reserve the right to make specification, equipment, and price changes without notice. Illustrations shown may include optional equipment and accessories and may not include all standard equipment.

Wir verbessern unsere Produkte ständig und integrieren den technischen Fortschritt. Aus diesem Grund behalten wir uns das Recht vor, die technischen Daten, die Ausstattungsdetails und die Preise unserer Maschinen ohne Vorankündigung zu ändern.

Du fait de sa politique d'amélioration constante de ses produits liée au progrès technique, la Société se réserve le droit de procéder sans préavis à des changements de spécifications, d'équipement ou de prix. Les illustrations peuvent comporter des équipements ou accessoires optionnels ou ne pas comporter des équipements standards.

El perfeccionamiento constante y el avance tecnológico hacen necesario que la empresa se reserve el derecho de efectuar cambios en las especificaciones, equipo y precios sin previo aviso. En las ilustraciones se puede incluir equipo y accesorios opcionales y es posible que no se muestre el equipo normal.

Distributed By: